

CARCASAS PARA CORREDERAS

Carcasas Zamak Regulables Rod. de Agujas

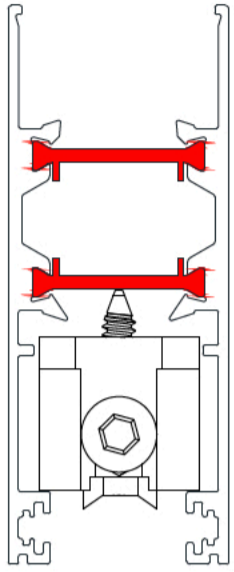

| | |
|--|-------|
| | INOX |
| | INOX |
| | AL |
| | NYLON |

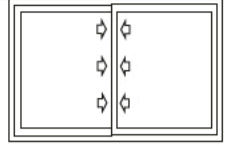
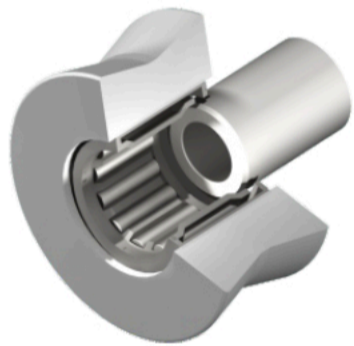
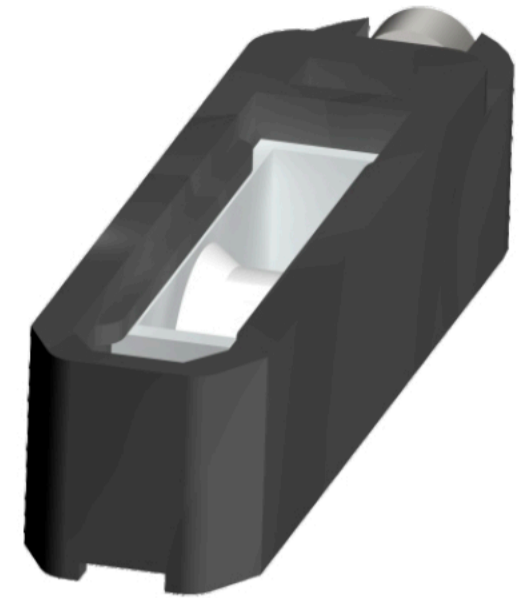
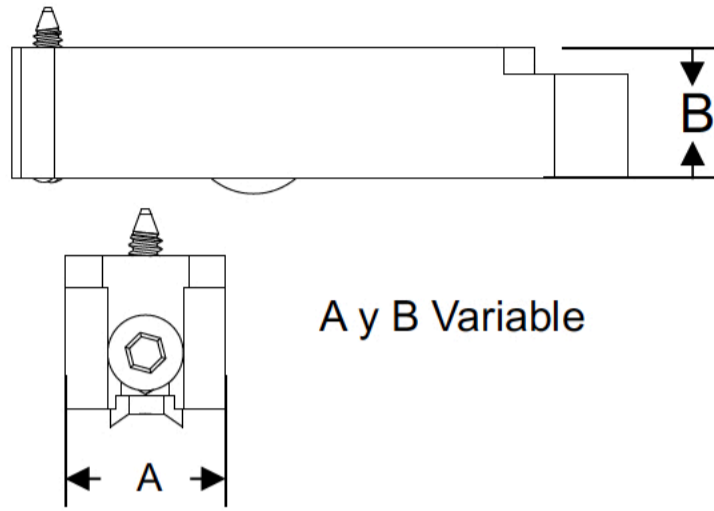

| | |
|---|----------------|
| 1 | DELRIN |
| 2 | Steel Acero |
| 3 | INOX |

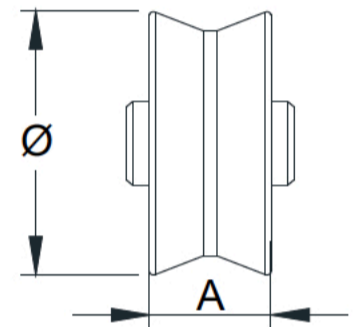
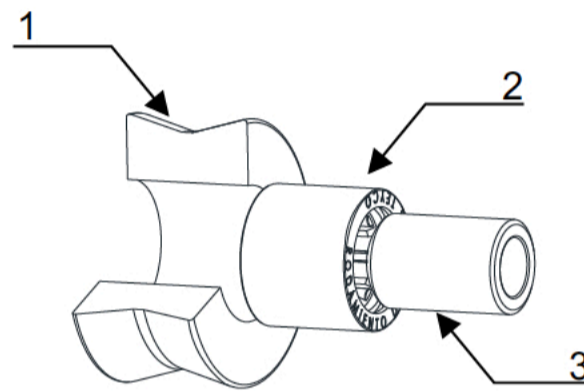

Ø= variable
A= variable

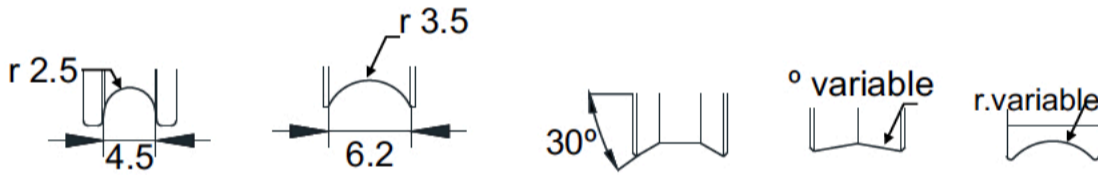

| Serie | Ref. | mm | | | | | Regulacion | mm | | |
|----------|------|------|-------|---|---|----|------------|----|-------|--|
| | | A | B | C | D | A | | Ø | Unid. | |
| S/PCW70 | 4130 | 22 | 26,8 | - | - | ±1 | 10 | 22 | 200 | |
| S/ALC-96 | 4135 | 22 | 22,25 | - | - | ±1 | 10 | 22 | 200 | |
| S/NC83. | 4137 | 27.9 | 26.8 | - | - | ±1 | 10 | 22 | 200 | |

ENSAYOS

| KM. | KG/RUEDA | VEL. |
|--------|----------|----------|
| 20 KM. | 50 KG | 2 MT/SG. |