

# CARCASAS PARA CORREDERAS

Carcasas plasticas fijas  
Fixed Nylon Roller - Chariot en Nylon Fixe

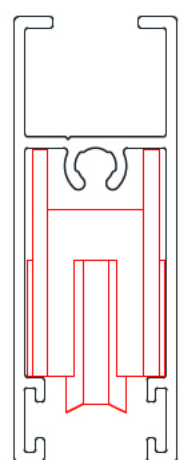

	Steel Acero
	Nylon

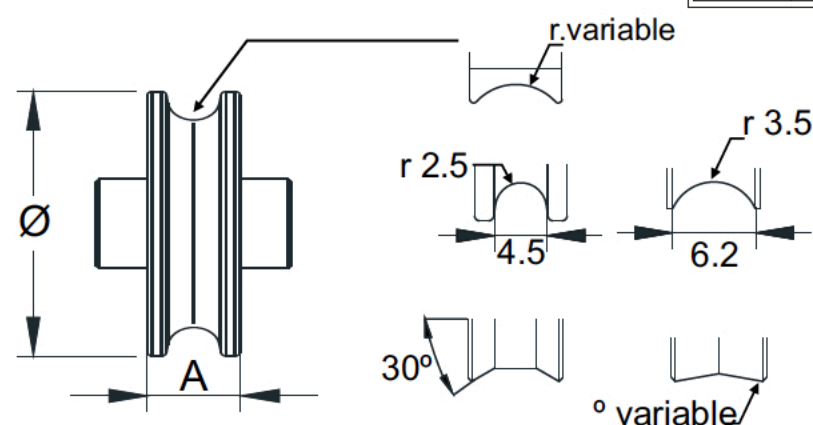
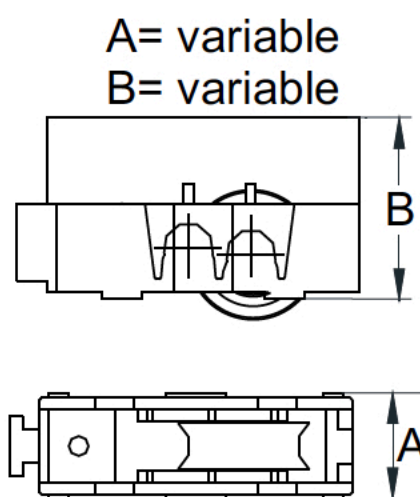
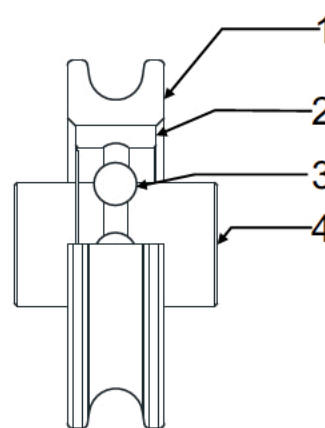

1	Nylon
2	Steel Acero
3	Steel Acero
4	Steel Acero

Serie	Ref.	mm					Regulacion	mm			Unid.
		A	B	C	D	A		Ø	Nº FILAS BOLAS		
S/TK-70,AL-24,ELITE	110	18,7	25,2	-	-	±0.5	7	26	1	400	
S/C-65	112	18.8	27	-	-	±0.5	7	20	1	400	
S/V60, 640,AL-21	113	16	26.7	-	-	0.5	7	20	1	1.000	
S/P-92	114	18.8	33	-	-	±1	7	28	1	600	
S/2300	115	15	25.3	-	-	0.5	7	20	1	1.000	
S/P-60	116	15	20.5	-	-	0.5	6	20	1	1.200	
S/FORMA-60	118	16	25	-	-	0.5	7	20	1	1.000	
S/C-95	121	17	26.8	-	-	0.5	7	20	1	1.000	